



# ECOFILM<sup>SET</sup>

underfloor heating element

*ECOFILM<sup>SET</sup> is part of the Flexel Underfloor Heating Systems product range by Flexel International Ltd, Queensway Ind Est, Glenrothes, Fife, KY7 5QF, Scotland.*

*Also available: ECOFLEX, ECOFLOOR & ECOFILM.*

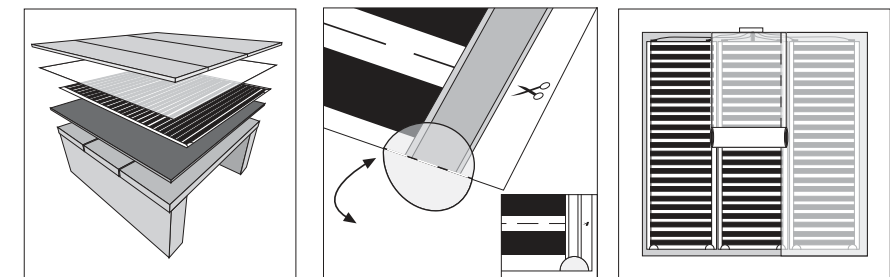

## COMPLETE INSTALLATION INSTRUCTIONS & GUARANTEE



T 01592 760928 F 01592 760929 W [www.flexel.co.uk](http://www.flexel.co.uk) E [enquiries@flexel.co.uk](mailto:enquiries@flexel.co.uk)

REV. 2.0

**the complete electric underfloor heating solution for wood and laminate floors**

### Laying the ECOFILM<sup>SET</sup> heating elements

Before commencing check the labels on each of the ECOFILM<sup>SET</sup> element cartons and the elements to ensure they are the correct sizes and power rating.

Following the plan prepared at the ordering stage and working from one side, roll out the first element copper side down with the connection leads closest to the thermostat wall and leaving a minimum 50mm gap from walls. Apply light finger pressure on the cable connection covers to leave an imprint on the ECOMAX-LITE, move the element to avoid damage and using a sharp knife remove the ECOMAX-LITE to allow the cable connection cover to sit flush with the ECOMAX-LITE surface (fig.4).

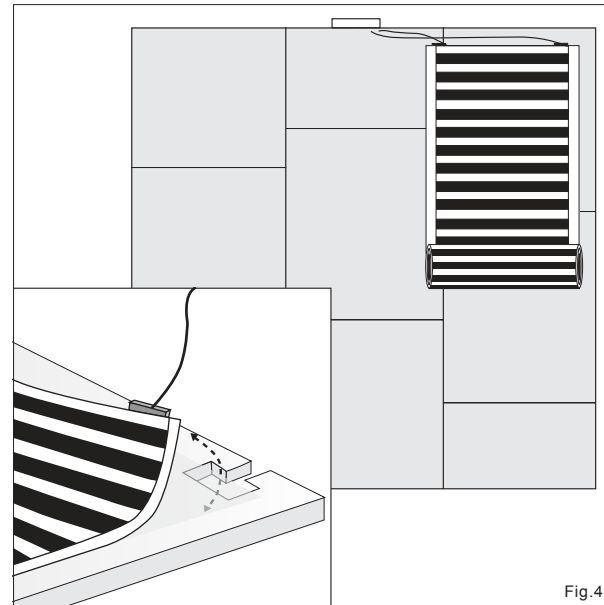

Fig.4

### Adjusting the ECOFILM<sup>SET</sup> heating elements

ECOFILM<sup>SET</sup> heating elements are available in standard lengths from 2.0m to 10.0m in 0.5m increments. Should the elements require to be shortened this can be easily done by cutting along the cutting line using a sharp knife and straight edge or scissors and insulating the copper strips using the insulating green polyester tape discs (4 of supplied with each heating element) as shown in the diagram (fig.5). Care should be taken not to cut closer than 3mm from the edge of the black heated area. Repeat the procedure for the remaining elements, butting adjacent elements edge to edge.

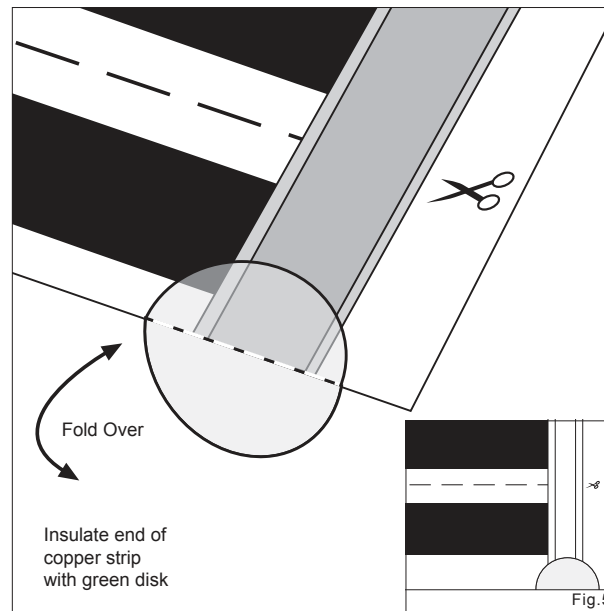
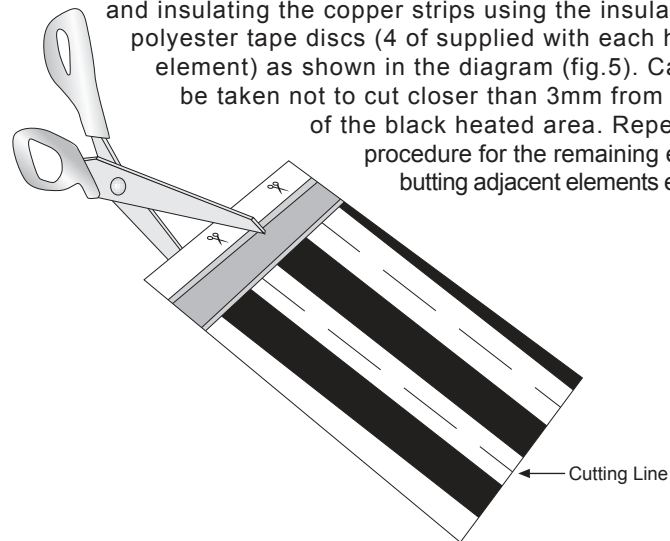

Fig.5

### Taping the ECOFILM<sup>SET</sup> heating elements

Tape along the edges of the heating elements using the ECOFILM<sup>SET</sup> fixing tape taking care not to damage the heating elements (20m<sup>2</sup> of heating element will require approximately 40m of tape).

Using a sharp knife, cut a channel in the ECOMAX-LITE along the connection lead/thermostat wall side to accommodate the connection leads (fig.6). Run the leads in the channel to the junction box and tape over using ECOFILM<sup>SET</sup> fixing tape (ADT50).

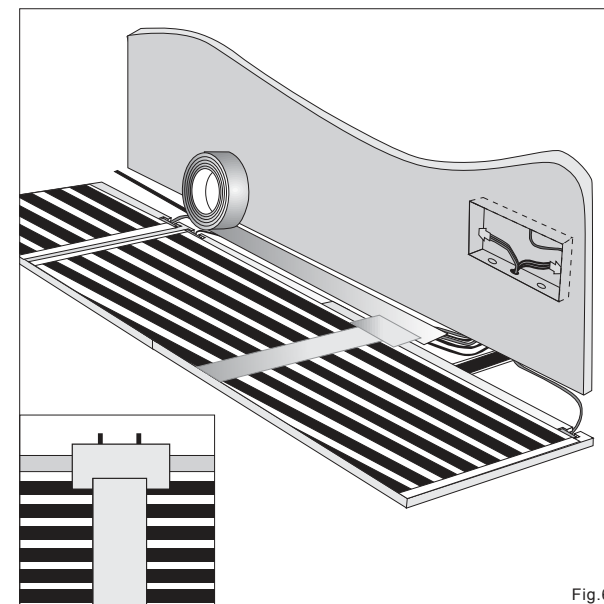

Fig.6

### Laying ECOFILM<sup>SET</sup> Polyester Vapour Barrier

The installed ECOFILM<sup>SET</sup> heating elements must be covered with the ECOFILM<sup>SET</sup> Polyester Vapour Barrier to provide optimum moisture and additional mechanical protection. ECOFILM<sup>SET</sup> Polyester Vapour Barrier (code PVB12 or PVB25) is available in 1m x 12 or 1m x 25m rolls which will cover approximately 10m<sup>2</sup> and 22m<sup>2</sup> respectively when installed.

To install, roll out the vapour barrier, cut to length and overlap adjacent pieces by a minimum of 100mm (fig.7). Tape along the entire length of the overlap using ECOFILM<sup>SET</sup> fixing tape (1 roll of vapour barrier will require approximately 25m of fixing tape). Always remember to cover the entire floor with the vapour barrier,

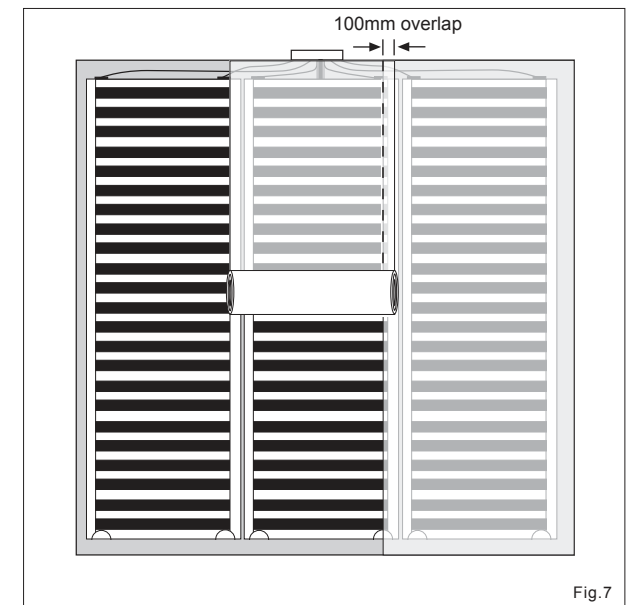

Fig.7

### Making The Connections

**Please note the following steps must only be carried out by a qualified electrician**

Using the graph paper supplied draw a sketch showing the approximate position, width and length of each ECOFILM<sup>SET</sup> heating element together with the thermostat sensor position and number each of the elements on the drawing.

ECOFILM<sup>SET</sup> heating elements are connected together using the new lever action ECOFILM<sup>SET</sup> connector. A separate connector is used for the live and neutral connections. A single pair of connectors will connect 4 ECOFILM<sup>SET</sup> elements to the thermostat output (fig.9). To connect up to 7 elements, 2 pairs of connectors will be required with each pair being connected together using a suitable link wire - maximum 2.5mm<sup>2</sup> solid or up to 4mm<sup>2</sup> fine stranded cable (fig.9).

Cut the element cables inside the junction box to approximately 100mm. Carefully strip back 10mm of the cable insulation taking care to completely remove the clear inner insulation.

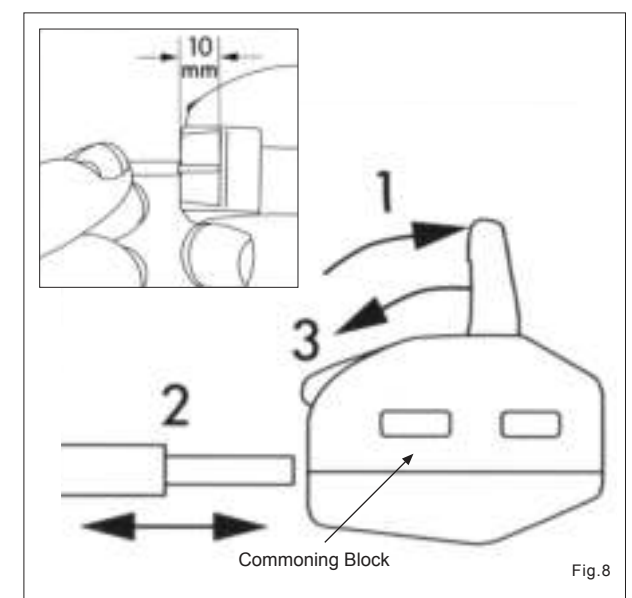

Fig.8

Measure and record on the test sheet the resistance of each element and carefully insert all brown and blue cables into separate commoning blocks as shown in the diagram (fig.8). A suitable cable (maximum 2.5mm<sup>2</sup> solid) will be required to connect the commoning blocks to the output of the temperature controller.

**Please note:** If the installed load exceeds the thermostat power rating then a suitable contactor must be used.

Measure and record the total installed load resistance and carry out an insulation check to ensure no damage to the elements has occurred during installation. A second insulation resistance measurement should be taken once the flooring has been laid.

**Finally, complete the test report and guarantee certificate ensuring all measurements are correctly recorded and leave all documentation including the thermostat instructions next to the electrical supply distribution board.**

**Remember the guarantee must be filled in and kept with a proof of purchase to ensure you are covered by our ten year guarantee.**

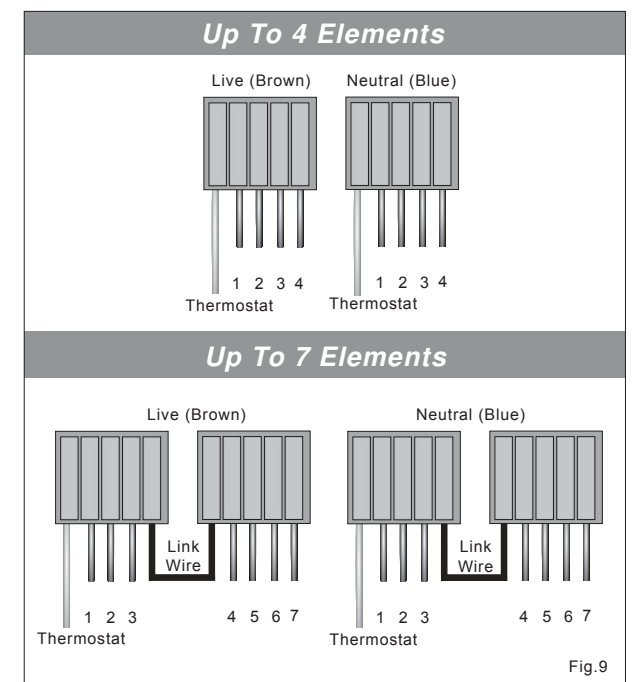
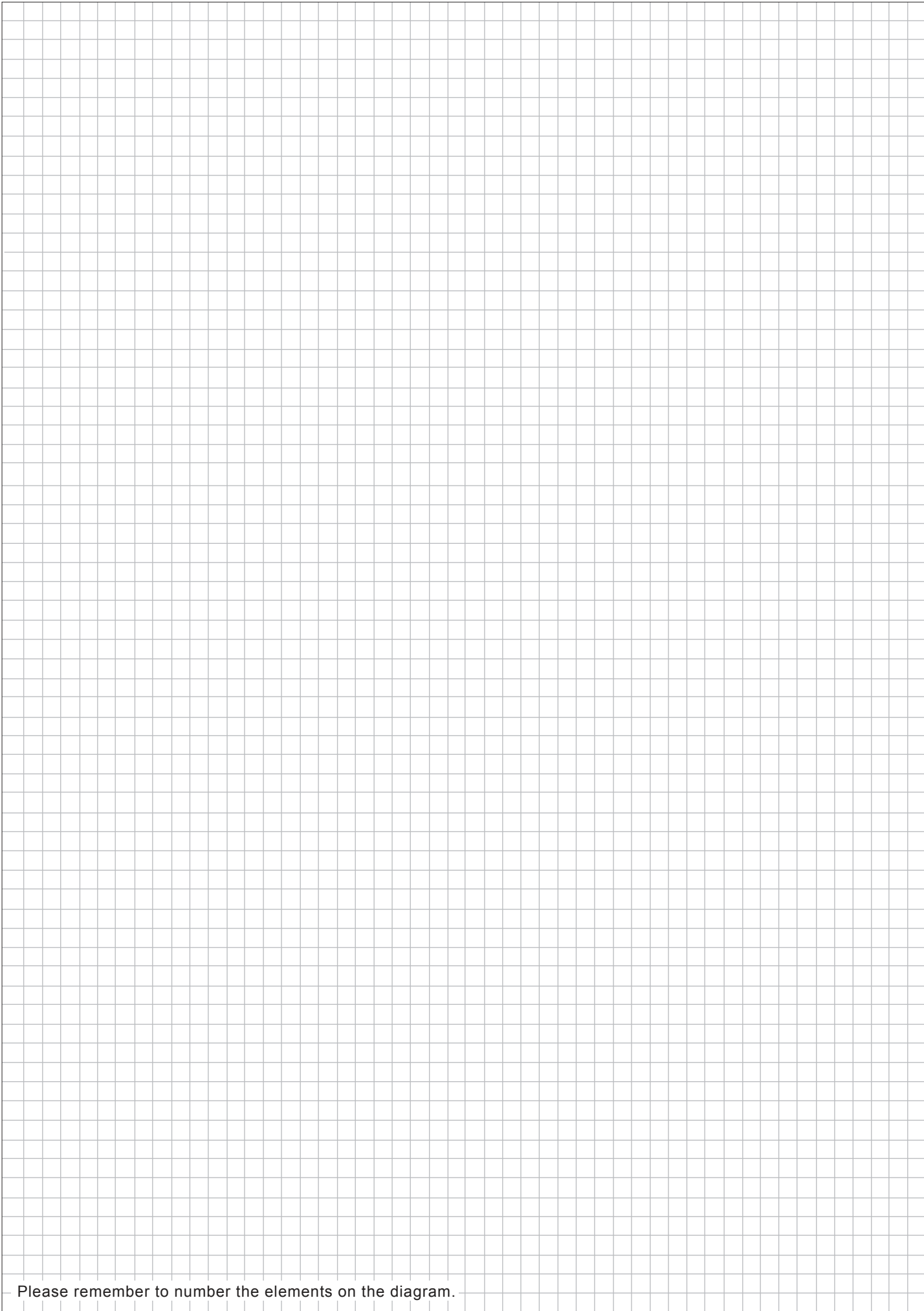

Fig.9





Please remember to number the elements on the diagram.

### Thermostat

**ECOFILM<sup>SET</sup>** thermostats should be positioned (fig.1) at a height approximately 1.5m from the floor in an area free from draughts, out of direct sunlight and close to the electrical supply. All **ECOFILM<sup>SET</sup>** thermostats have a floor sensor which is placed in the supplied protective plastic conduit and positioned centrally below one of the heating elements at a distance of approximately 0.5m from the wall. A single gang flush fitting minimum 25mm deep back box (35mm preferred) will be required for the controller.

### Junction Box Installation

A junction box (fig.1, preferably 2 gang x minimum 25mm deep) is required for commoning up the **ECOFILM<sup>SET</sup>** heating element 5m long connection leads. This should be sited close to the thermostat and in a position to enable all the connection leads and the thermostat sensor conduit to reach the box comfortably.

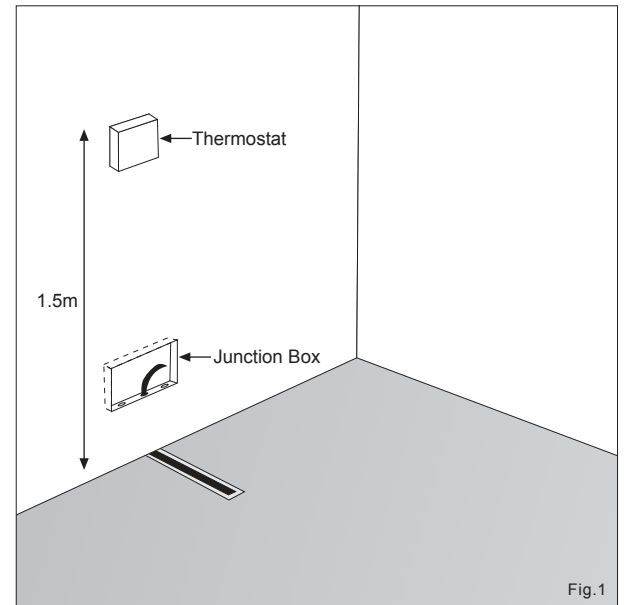

### Floor Sensor Installation

Cut a 13mm wide by 6-7mm deep channel in the subfloor (fig.2) to accommodate the sensor conduit so that top of the conduit will be level with the ECOMAX-LITE thermal insulation surface when installed (see fig. 2). Tape over the end of the conduit using a small piece of **ECOFILM<sup>SET</sup>** fixing tape. Place the conduit in the channel and feed the end into the junction box. The conduit can now be cut to length leaving approximately 5cm inside the junction box. Slide the sensor into the conduit until the sensor bulb reaches the taped end. Wrap a piece of tape around the conduit and sensor cable to prevent the sensor being accidentally pulled out. Use **ECOFILM<sup>SET</sup>** fixing tape (ADT50) to hold the conduit in place in the channel.

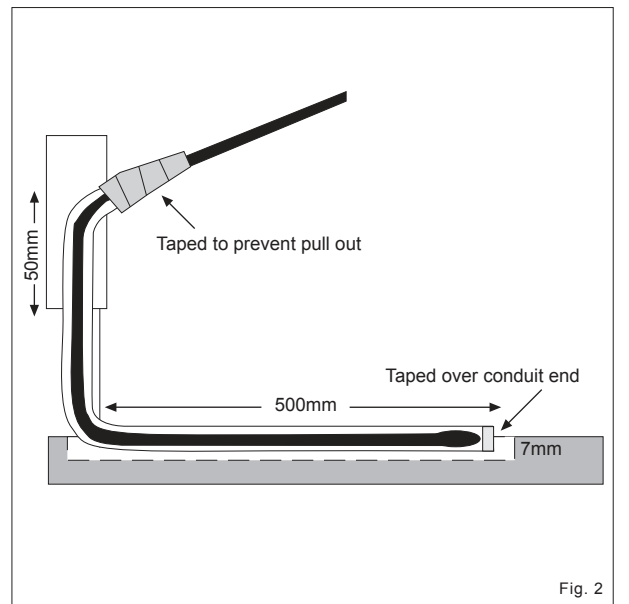

### Laying The ECOMAX-LITE Thermal Insulation

Thoroughly clean the existing floor area taking care to remove any sharp objects.

Lay the ECOMAX-LITE sheets in "brick work" fashion as illustrated in the drawing (fig.3). Always remember to cover the total floor area with ECOMAX-LITE even unheated areas. Tape along the edges using **ECOFILM<sup>SET</sup>** fixing tape (20m<sup>2</sup> of ECOMAX-LITE will require approximately 35m of fixing tape). Carefully cut a channel in the ECOMAX-LITE at the position of the sensor conduit channel using a sharp knife and straight edge. Tape over the conduit using **ECOFILM<sup>SET</sup>** fixing tape (ADT50).

